

WS... series split-core type measuring current transformers

WS...-8000 series split-core type measuring current transformers



WS50x80 measuring current transformer
WS50x80-8000 measuring current transformer



WS50x80 split-core type
WS50x80-8000 split-core type

Product description

WS... and WS...-8000 series split-core type measuring current transformers can be opened using the interlock knob to enclose the conductors to be monitored. That allows easy retrofitting in existing installations.

WS... und WS...-8000 series measuring current transformers are highly sensitive measuring current transformers of split-core type which in combination with RCM and RCMS series residual current monitors and evaluators convert AC currents into evaluable measurement signals.

In addition, the measuring current transformers can be used in combination with insulation fault location systems (EDS) for IT systems. They are designed to measure the test current generated by a PGH insulation fault test device or an A-ISOMETER® IRDH. In combination with EDS series insulation fault evaluators the test current is converted into evaluable signals.

Connection to the respective devices is via a two-wire cable.

Installation instructions

- Make sure that all live conductors are routed through the measuring current transformer
- Do not route shielded conductors through the measuring current transformer
- Never route a PE conductor through the measuring current transformer!

Wiring diagram

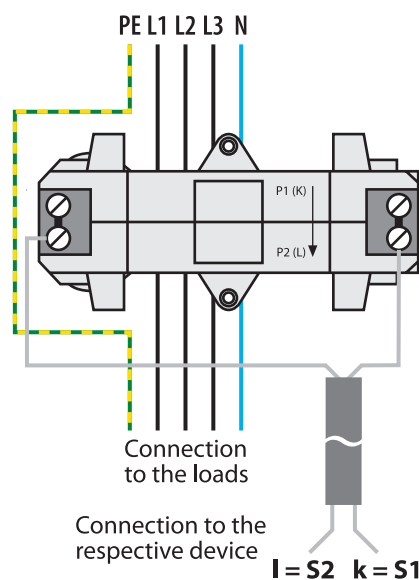

WS... measuring current transformer

Connection to the respective RCMS series residual current monitoring system, RCM series residual current monitor or EDS series insulation fault location system

WS...-8000 measuring current transformer

Connection to the respective insulation fault evaluators EDS473(E)-12, EDS474(E)-12, EDS461 and / or EDS491

Device features

WS... measuring current transformer

- For RCMS460 / 490 series residual current monitoring systems
- For RCM420, RCM460 and RCM470 series residual current monitors
- For EDS460 / 490 and EDS470 series insulation fault location systems

WS...-8000 measuring current transformer

- For EDS473(E)-12, EDS474(E)-12, EDS461 and EDS491 series insulation fault evaluators

Approvals and certifications



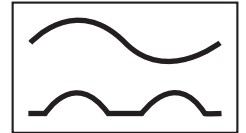

Technical data

Insulation coordination acc. to IEC 60664-1 / IEC 60664-3

Rated insulation voltage	800 V
Rated impulse voltage / pollution degree	8 kV / III

CT circuit WS...

Rated primary residual current	30 mA... 10 A
Rated secondary residual current	0.0167 A
Rated transformation ratio K_n	10 / 0.0167 A
Rated burden	$\leq 180 \Omega^*$
Nominal power	0.05 VA
Frequency range	42 Hz... 3 kHz
Rated continuous thermal current I_{cth}	40 A
Rated short-time thermal current I_{tth}	2.4 kA / 1 s
Rated dynamic current I_{dyn}	6.0 kA / 40 ms

CT circuit WS...-8000

Rated primary residual current	30 mA... 1 A
Rated secondary residual current	0.000125 A
Rated transformation ratio K_n	10 / 0.000125 A
Rated burden	2400 Ω
Nominal power	0.0375 VA
Frequency range	42 Hz... 3 kHz
Rated continuous thermal current I_{cth}	6 A
Rated short-time thermal current I_{tth}	60 x $I_{cth} = 0.36 \text{ kA} / 1 \text{ s}$
Rated dynamic current I_{dyn}	2.5 x $I_{tth} = 0.9 \text{ kA} / 40 \text{ ms}$

Environmental conditions

Operating temperature	-10 °C... +70 °C
Climatic class acc. to IEC 60721	
Stationary use (IEC 60721-3-3)	3K5 (except condensation and formation of ice)
Transport (IEC 60721-3-2)	2K5 (except condensation and formation of ice)
Long-time storage (IEC 60721-3-1)	1K5 (except condensation and formation of ice)
Classification of mechanical conditions IEC 60721	
Stationary use (IEC 60721-3-3)	3M4
Transport (IEC 60721-3-2)	2M2
Long-time storage (IEC 60721-3-1)	1M3

Connection

Connection type	screw-type terminals
rigid / flexible / conductor sizes	0.08...2.5 / 0.08...2.5 mm ² / 28...12 AWG
Stripping length	8...9 mm

Connection EDS, RCM(S) measuring current transformers

Single wire $\geq 0.75 \text{ mm}^2$	0...1 m
Single wire twisted $\geq 0.75 \text{ mm}^2$	0...10 m
Shielded cable $\geq 0.5 \text{ mm}^2$	0...40 m
Recommended cable	J-Y (ST) Y min. 2 x 0.8 (shielded, shield on one side connected to I-conductor, not connected to earth)

Other

Degree of protection, internal components (IEC 60529)	IP40
Degree of protection, terminals (IEC 60529)	IP20
Screw mounting	M5 with mounting brackets
Flammability class	UL94V-0
Product standards	IEC 60044-1
Operating manual WS...	TBP409015
Operating manual WS...-8000	TBP108018

*The rated burden may vary depending on the respective device data sheet.

Ordering information

Type	Inside dimensions	Mounting brackets	Art. No.
WS20x30	20 x 30 mm	×	B 9808 0601
WS50x80	50 x 80 mm	×	B 9808 0603
WS80x120	80 x 120 mm	×	B 9808 0606
WS20x30-8000*	20 x 30 mm	×	B 9808 0602
WS50x80-8000*	50 x 80 mm	×	B 9808 0604

Dimension diagram

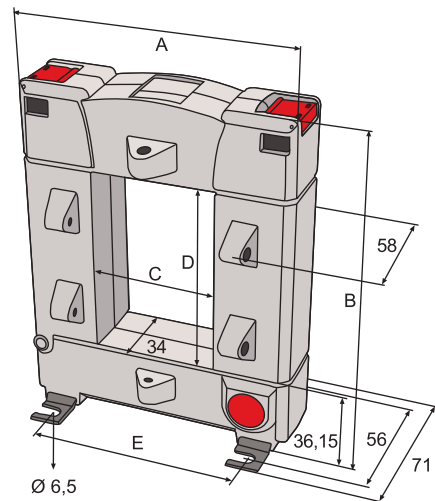

Dimensions

Type	A	B	C	D	E	Weight
WS20x30	93	106.15	23	33	64	$\leq 0.6 \text{ kg}$
WS50x80	125	158.15	55	85	96	$\leq 1.04 \text{ kg}$
WS80x120	155	198.15	85	125	126	$\leq 1.4 \text{ kg}$
WS20x30-8000*	93	106.15	33	33	64	$\leq 0.63 \text{ kg}$
WS50x80-8000*	125	158.15	85	85	96	$\leq 1.08 \text{ kg}$

Dimensions in mm

Selection list

Type	RCM420	RCM470	RCMS460	RCMS470	EDS460	EDS461	EDS470	EDS473	EDS474
			RCMS490		EDS490	EDS491			
WS20x30	×	×	×	×	×	--	×	--	--
WS50x80	×	×	×	×	×	--	×	--	--
WS80x120	×	×	×	×	×	--	×	--	--
WS20x30-8000*	--	--	--	--	--	×	--	×	×
WS50x80-8000*	--	--	--	--	--	×	--	×	×

* For insulation fault locations systems of the EDS461 / 491 and EDS473 / 474 series